

# SSM TT-3

## INSTRUCTION MANUAL



### WARNING!

TO REDUCE THE RISK OF INJURY, USER MUST READ AND UNDERSTAND THIS INSTRUCTION MANUAL.

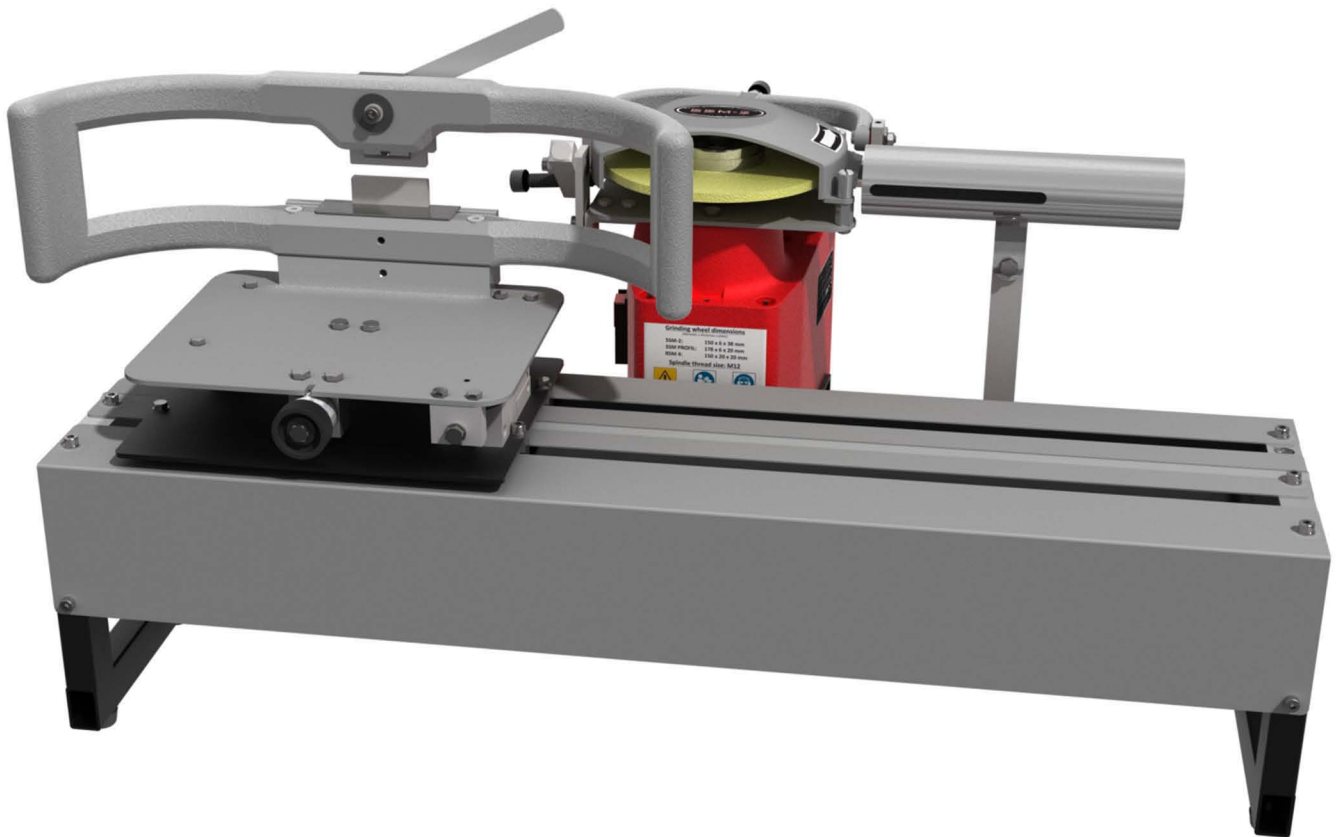

### ORIGINAL INSTRUCTIONS



Date of purchase: .....



# SSM TT-3 skate sharpening station

***Congratulations on your purchase of a SSM TT-3 skate sharpening station.  
We sincerely thank you for selecting a product from SSM Produkt AB.***

***To obtain an additional copy of this manual, please contact SSM at:***



**SSM PRODUKT AB**

Vaksala-Eke  
SE-755 94 Uppsala, Sweden

Tel: +46 (0)18 500840

E-mail: [ssm.produkt.ab@telia.com](mailto:ssm.produkt.ab@telia.com)

Internet: [www.ssmprodukt.com](http://www.ssmprodukt.com)

## TABLE OF CONTENTS

Limited Warranty.....	2
General Safety Rules.....	3-4
Specific Safety Rules and Symbols.....	5
Functional Description.....	6-7
Assembly.....	8
Operation.....	9-11
Maintenance.....	12-13
Technical Specifications and Dimensions.....	13
Accessories.....	14

## LIMITED WARRANTY



### Scope of warranty

This warranty covers any defects in materials and workmanship under normal use.

### Period of coverage

This warranty runs for two (2) years from the date of purchase. Please save your receipt or invoice.

### Limitations

Failures due to abuse, misuse or an event or effect that cannot be reasonably anticipated or controlled (such as flood, earthquake, act of God etc.) are not covered by this warranty. Surface coating problems caused by excessive humidity, in-use scratches or abrasions, and direct exposure to the elements are also not covered.

*Repair or replacement is the only option available under this warranty. SSM Produkt AB (SSM) is not responsible for damages of any kind, including incidental and consequential damages.*

Incidental damages include but are not limited to such damages as loss of time and loss of use. Consequential damages include but are not limited to the cost of repairing or replacing property that was damaged if the product from SSM does not work properly.

### Correction of details

If your product cannot be repaired, we will replace your product free of charge.

### How to get service

Please return the defective product together with the purchase receipt or the invoice. You can obtain service by contacting a dealer of SSM products or SSM directly. At our discretion, the dealer or SSM will either repair or replace your product.

### How country and state laws relates to the warranty

This warranty gives you specific legal rights. You may also have other rights that vary from country to country and from state to state.

**SSM PRODUKT AB RESERVES THE RIGHT TO MAKE IMPROVEMENTS  
AND MODIFICATIONS TO DESIGN WITHOUT PRIOR NOTICE.**

**SSM PRODUKT AB  
VAKSALA-EKE, SE-75594, UPPSALA, SWEDEN**

# GENERAL SAFETY RULES



## WARNING!

**When using electric tools basic safety precautions should always be followed to reduce the risk of fire, electric shock and personal injury including the following.**

**Read all these instructions before attempting to operate this product and save these instructions.**

### Safe Operation

*Keep your work area clear.*

- Cluttered areas and benches invite injuries.

*Consider work area environment.*

- Do not expose tools to rain.
- Do not use tools in damp or wet locations.
- Keep work area well lit.
- Do not use tools in the presence of flammable liquids or gases.

*Guard against electric shock.*

- Avoid body contact with earthed or grounded surfaces (i.e. pipes, radiators, ranges, refrigerators).

*Keep other persons away.*

- Do not let persons, especially children, not involved in the work touch the tool or the extension cord and keep them away from the work area.

*Store idle tools.*

- When not in use, tools should be stored in a dry locked-up place, out of reach of children.

*Do not force the tool.*

- It will do the job better and safer at the rate for which it was intended.

*Use the right tool.*

- Do not force small tools to do the job of a heavy duty tool.
- Do not use tools for purposes not intended; for example do not use circular saws to cut tree limbs or logs.

*Dress properly.*

- Do not wear loose clothing or jewelry; they can be caught in moving parts.
- Non-skid footwear is recommended when working outdoors.
- Wear protective hair covering to contain long hair.

*Use protective equipment.*

- Use safety glasses and hearing protection.
- Use face or dust mask if working operations create dust.

*Connect dust extraction equipment.*

- If the tool is provided for the connection of dust extraction and collecting equipment, ensure these are connected and properly used.

*Do not abuse the cord.*

- Never yank the cord to disconnect it from the socket. Keep the cord away from heat, oil and sharp edges.

*Secure work.*

- Where possible use clamps or a vice to hold the work. It is safer than using your hand.

*Do not overreach.*

- Keep proper footing and balance at all times.



# GENERAL SAFETY RULES (continued)

## *Maintain tools with care.*

- Keep cutting tools sharp and clean for better and safer performance.
- Follow instruction for lubricating and changing accessories.
- Inspect tool cords periodically and if damaged have them repaired by an authorized service facility.
- Inspect extension cords periodically and replace if damaged.
- Keep handles dry, clean and free from oil and grease.

## *Disconnect tools.*

- When not in use, before servicing and when changing accessories such as blades, bits and cutters, disconnect tools from the power supply.

## *Remove adjusting keys and wrenches.*

- Form the habit of checking to see that keys and adjusting wrenches are removed from the tool before turning it on.

## *Avoid unintentional starting.*

- Ensure switch is in "off" position when plugging in.

## *Use outdoor extension leads.*

- When the tool is used outdoors, use only extension cords intended for outdoor use and so marked.

## *Stay alert.*

- Watch what you are doing, use common sense and do not operate the tool when you are tired.

## *Check damaged parts.*

- Before further use of tool, it should be carefully checked to determine that it will operate properly and perform its intended function.
- Check for alignment of moving parts, binding of moving parts, breakage of parts, mounting and any other conditions that may affect its operation.
- A guard or other part that is damaged should be properly repaired or replaced by an authorized service center unless otherwise indicated in this instruction manual.
- Have defective switches replaced by an authorized service center.
- Do not use the tool if the switch does not turn it on and off.

## *Warning.*

- The use of any accessory or attachment or performance of any operation with this tool other than those recommended in this instruction manual may present a risk of personal injury.

## *Have your tool repaired by a qualified person.*

- This electric tool complies with the relevant safety rules. Repairs should only be carried out by qualified persons using original spare parts; otherwise this may result in considerable danger to the user.

## *Noise*

- The typical A-weighted noise levels determined according to EN 61029-1:2009 :

Sound pressure level ( $L_{PA}$ ): 80 dB

Sound power level ( $L_{WA}$ ): 93 dB

Uncertainty (K): 2,5 dB

## EC-DECLARATION OF CONFORMITY

We, SSM PRODUKT AB, Vaksala-Eke, SE-755 94, Uppsala, Sweden declare that the product SSM TT-3 to which this declaration relates is in conformity with the following standards:

EN 61029-1:2009

EN 55014-1:2006

EN 61000-3-2:2006

EN 61000-3-3:2008

EN 55014-2:1997+A1:2001+A2:2008



Uppsala, November 21, 2014  
(place, date)

Stefan Gustavsson  
(signature, name)

following the provisions of 2004/108/EC, 2006/42/EC and 2006/95/EC directives.

# SPECIFIC SAFETY RULES AND SYMBOLS



**WARNING!**



**READ OPERATOR'S  
MANUAL BEFORE USING  
THE MACHINE**



**EYE AND HEARING  
PROTECTION REQUIRED**

The machine must be used only for the purpose of grinding skate blades.

Always fasten the skate in the skate holder. NEVER hold skate being sharpened only by your hands.

*It is important to support the work properly to get the best result possible, minimize body exposure and loss of control.*

Check grinding wheel protective cover for proper fit before using the machine to minimize the risk of flying debris. Keep hands and body away from the rotating grinding wheel.

*Contact with a rotating grinding wheel or parts from an exploding grinding wheel can result in serious injury.*

Only use grinding wheels approved by SSM Produkt AB. Use grinding wheels with correct size and shape.

*Unauthorized grinding wheels may be dangerous!*

Keep grinding wheel securely fastened.

When fastening grinding wheel, never use damaged or incorrect flange, flange washer or nut.

*The flange and flange washer were specially designed for the machine, for optimum performance and safety of operation.*

## **Safety Warnings Specific for Grinding:**

Use only wheel types that are recommended for your power tool and the specific guard designed for the selected wheel. *Wheels for which the power tool was not designed cannot be adequately guarded and are unsafe.*

The guard must be securely attached to the power tool and positioned for maximum safety, so the least amount of wheel is exposed towards the operator.

*The guard helps to protect operator from broken wheel fragments and accidental contact with wheel.*

Wheels must be used only for recommended applications. For example: do not grind with the side of cut-off wheel. *Abrasive cut-off wheels are intended for peripheral grinding, side forces applied to these wheels may cause them to shatter.*

Always use undamaged wheel flanges that are of correct size and shape for your selected wheel.

*Proper wheel flanges support the wheel thus reducing the possibility of wheel breakage. Flanges for cut-off wheels may be different from grinding wheel flanges.*

Do not use worn down wheels from larger power tools.

*Wheel intended for larger power tool is not suitable for the higher speed of a smaller tool and may burst.*

# FUNCTIONAL DESCRIPTION

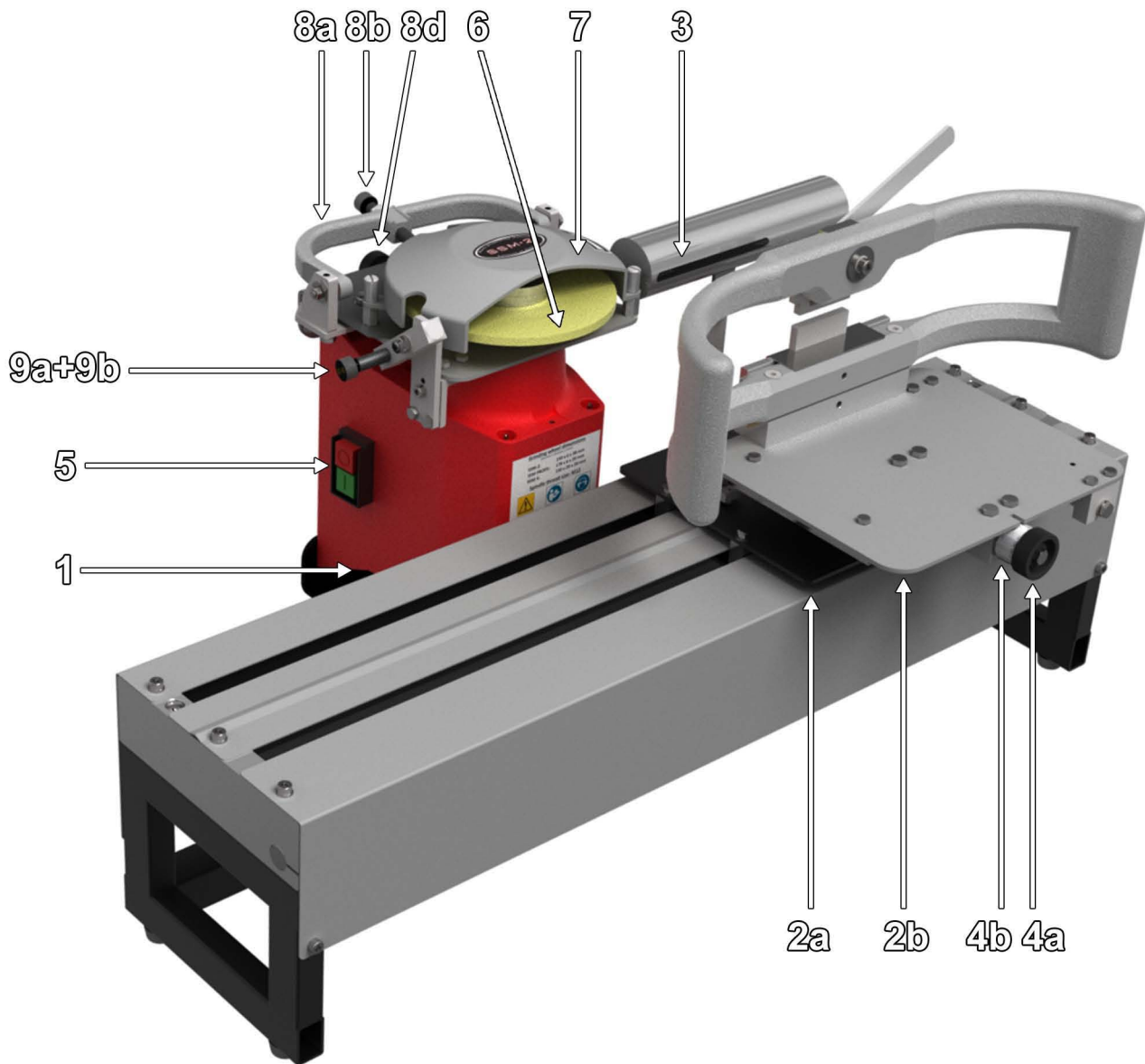

- 1. Locking device for transport
- 2a. Lower table construction
- 2b. Upper table with holder
- 3. Extractor tube
- 4a. Adjusting device
- 4b. Scale wheel for holder
- 5. Power switch
- 6. Grinding wheel

- 7. Protective cover
- 8a. Pivot device
- 8b. Diamond for hollow shape
- 8c. Ruler (on backside)
- 8d. Adjusting screw
- 9a. Flat surface device
- 9b. Diamond for plane shape



# FUNCTIONAL DESCRIPTION (continued)

The machine is intended to do the final sharpening on skate blades (flat or hollow).

This is done by manually moving the skate blade (mounted in a holder) against a suitably dressed, rotating grinding wheel. The open construction of the machine allows for constant and easy supervision of the sharpening process.

A bottom frame carries a modified electric motor and a moving table construction. The bottom frame must be kept horizontal. The electric motor is attached to a bottom plate. It is intended that the bottom plate be kept horizontal. The axle of the electric motor will then be vertical. On the axle the following items are mounted in this order: a flange, a grinding wheel, a flange washer, a balancing ring and a fastening nut. This is all partially covered by a protective cover. The "lower table construction" carries the "upper table" which in its turn carries a "skate holder".

1. The Locking device can be used to fasten the tables during transport to protect the machine. Attach or dismount as described later in this manual.
- 2a. The lower table construction is used as a base to move the skate holder in the left and right direction.
- 2b. The upper table is used as a base to move the skate holder inwards and outwards.
3. The Extractor tube is intended to collect sparks and other debris created when grinding and dressing. Fasten it onto the bottom frame with the wing nut in the angle you prefer; then attach a suitable dust extractor.
- 4a. The Adjusting device is used to get the hollowness on your skate centered by controlling the vertical position of the skate holder.
- 4b. The Scale wheel ranges from 2.5 - 4.2 mm and 7.8 - 8.2 mm. Turn it to the skate blade thickness value to center the hollow sharpening underneath the skate.
5. The Power switch is used to turn the machine on and off.
6. The Grinding wheel rotates counter-clockwise and is used to sharpen the skate blade. Use grinding wheel S-2/HP70, S-2/ME60, S-2/K80 or S-2/60.
7. The Protective cover is a guard that protects if a grinding wheel would break. It also prevents sparks from spreading. The protective cover is fastened by three top nuts.
- 8a. The Pivot device is used with a diamond to dress the grinding wheel for hollow sharpening. Use the nut to fasten the diamond.
- 8b. Use diamond D-80 or SD-80.
- 8c. The Ruler (scale in mm/inch.) is used when measuring on the pivot device. Measure from the head of the diamond screw to the pivot; the distance gives the hollowness obtained on your skate. See "ADJUSTMENTS".
- 8d. The Adjusting screw is used to move the pivot device inwards or outwards. This is done by screwing it clockwise (outwards) or counter clockwise (inwards).

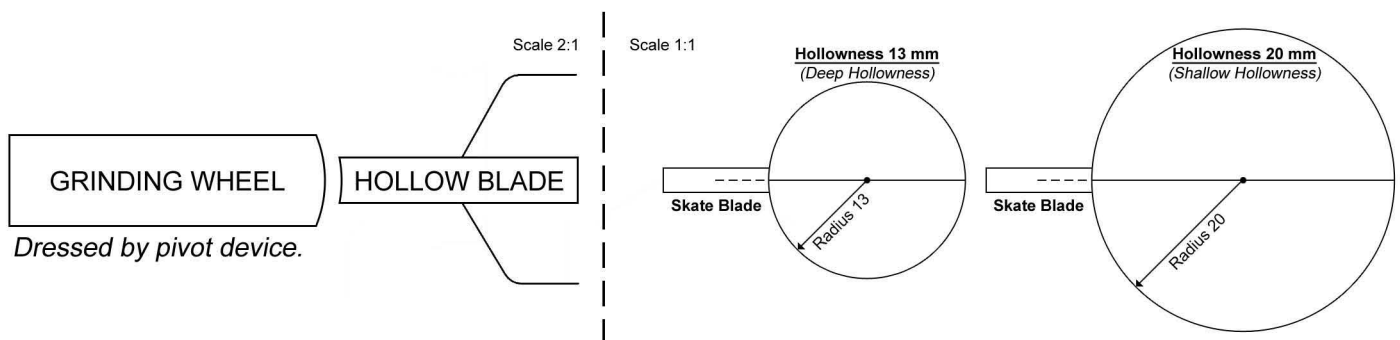

- 9a. The Flat surface device is used with a diamond to dress the grinding wheel for flat sharpening.
- 9b. Use diamond SD-50, SD-80 or D-80.

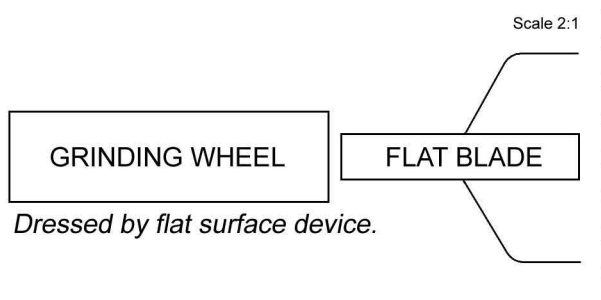

# ASSEMBLY

Your skate sharpening station SSM TT-3 is delivered complete and protected inside its delivery box. Remove all contents from the box and inspect to ensure no damage was incurred during shipping. Your SSM TT-3 package should also include the following:

DESCRIPTION	PART	#QTY
Instruction manual	SSM TT-3 manual.en	1
Exhaust tube	UT	1
Allen screw driver	AS 2.5 mm	1
Allen screw driver	AS 4 mm	1
Double ended wrench	DEW 8,10 mm	1

## Getting started:



### CAUTION!

IF POSSIBLE, ALWAYS DISCONNECT THE SKATE SHARPENING MACHINE FROM THE POWER SOURCE BEFORE MAKING ADJUSTMENTS.

Place the machine on a stable, level surface.

Dismount the transport locking device (1) and remount it in the same part (in the hole on the side of the machine).



The machine comes with a grinding wheel mounted and balanced. Refer to MAINTENANCE: HOW TO CHANGE AND BALANCE THE GRINDING WHEEL (on page 12) if you want to replace or balance the grinding wheel.

The grinding wheel and the diamond are adjusted for a hollow radius of 20 mm when delivered from SSM Produkt AB. Refer to OPERATION: ADJUSTMENTS (on page 9) if you want to change the radius.

MAKE SURE THAT NO DIAMOND IS TOUCHING THE GRINDING WHEEL WHEN YOU START THE MACHINE. If necessary, reposition the diamonds outwards. For diamond (9b), screw it directly. For diamond (8b), screw on the adjusting screw (8d).

MAKE SURE THAT THE HOLDER IS NOT TOUCHING THE GRINDING WHEEL WHEN YOU START THE MACHINE. Follow the instructions under OPERATION: ADJUSTMENTS (on page 9) to reposition the skate holder if necessary.

Attach a proper dust extractor to the extractor tube (3). This will reduce the amount of sparks and debris. For more complete protection, wear a suitable face mask covering mouth and nose.

Make sure you wear protection glasses and hearing protection when you use the machine.



# OPERATION

## ADJUSTMENTS before sharpening

### Balancing grinding wheel

If necessary, exchange the grinding wheel. Balance it if needed. (See MAINTENANCE: HOW TO CHANGE AND BALANCE THE GRINDING WHEEL.)

### Adjust the adjusting device on the holder

To get the sharpening centered underneath the skate blade you need to adjust the height of the adjusting device (4a). Measure the skate blade width and turn the scale wheel to that measurement (4b). The sharpening will now be centered. (In the image the device is set at 2.8 mm.)

*Please note that the lower jaw on the skate holder will not follow the movement of the adjusting device. You need to manually push it down after you have turned the scale wheel to a wider skate blade width.*

*When turning it to a narrower skate blade width the lower jaw will follow.*

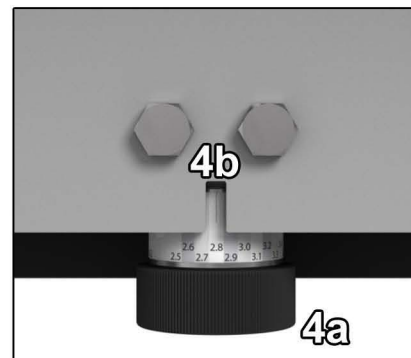

### Dressing the grinding wheel

To dress for hollowness, use diamond (8b) in the pivot device (8a). You adjust the hollowness by screwing the diamond in or out until you reach the correct position. You use the ruler (8c) to measure from inside the head of the diamond screw (must be a D-80 or a SD-80) to the pivot device (see Fig. A). The usable limits are 8 to 38 mm. Secure the diamond in place by tightening the nut on the diamond screw.

As you dress the grinding wheel, it is consumed and gets smaller. Use the adjusting screw (8d) to move the whole assembly with the pivot device. Move in small amounts, at the same time turning the pivot device up and down until a few times when dressing occurs. The dressing should be performed gently, so as not to damage diamond or grinding wheel.

To dress flat, use diamond (9b). Screw the diamond inwards in small amounts, at the same time turning the flat surface device (9a), so that its diamond moves up and down past the grinding wheel. The last few movements should give dressing. Dress gently.

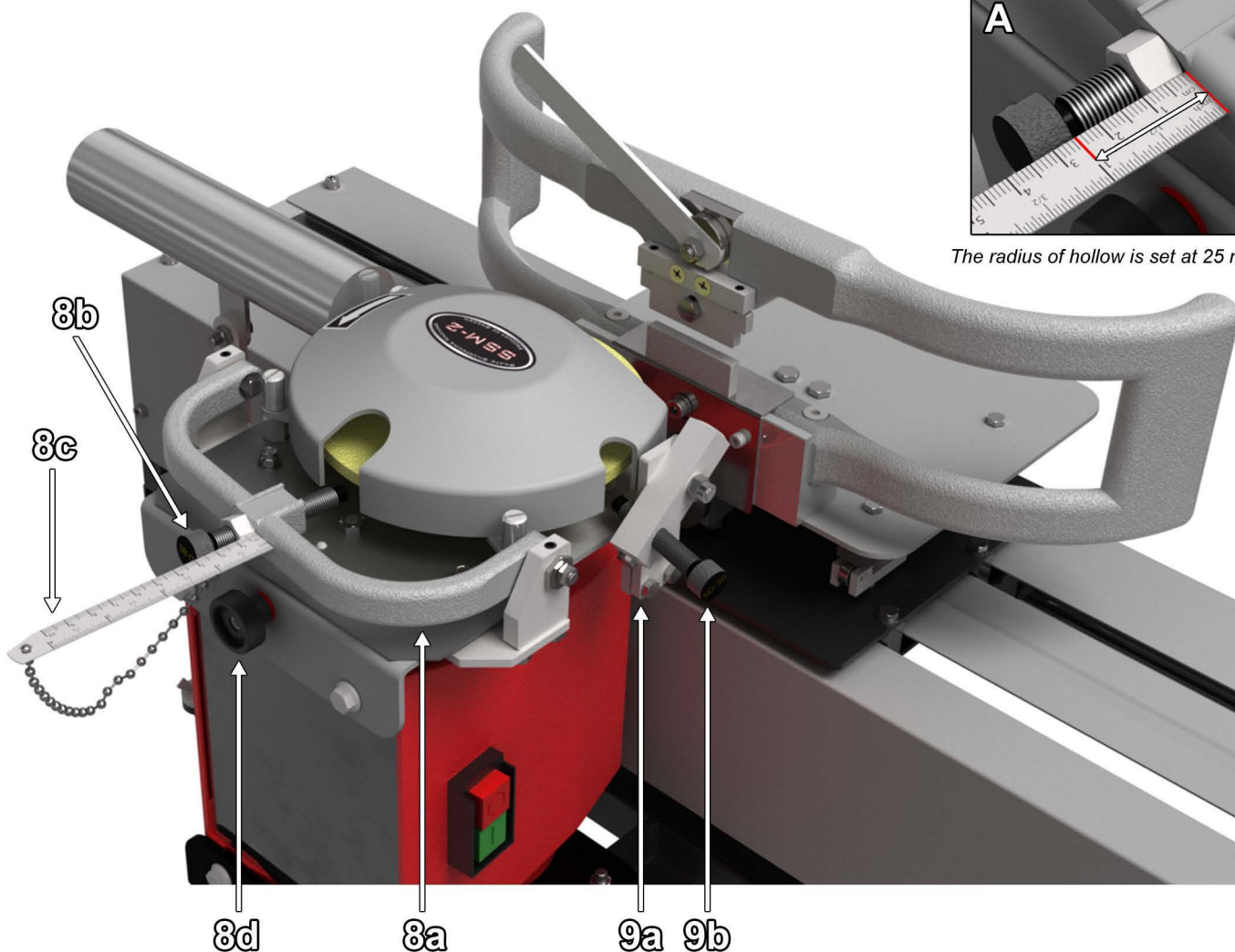

# OPERATION (continued)

## HOW TO CHECK IF THE HOLLOWNESS IS CENTERED

It is important that you get the hollowness centered on the blade. With the adjusting device the hollowness will always be centered if you turn it to the same number as the skate blade width (as long as the skate blade is straight).

An easy way of checking if the sharpening is centered is to use the **BEC, Blade Edge Checker** (check the separate BEC instruction paper how to use it).

In case you need to adjust the settings of the machine, please contact us and we will guide you.



## HOW TO ADJUST THE FLAT SURFACE DEVICE

The flat surface device comes with correct setting from the factory. If necessary, it can be adjusted by loosening the lock screw and correcting the angle using the adjustment screw.

You check for correctness of the angle between the sharpened flat surface and the two sides of the skate blade as follows: Dress the grinding wheel flat. The sharpen a skate. Use a BEC (Blade Edge Checker) to see if the flat surface is perpendicular to the two sides of the blade. The scales of the BEC indicate if the adjustment is correct or not. The scales also indicate the amount of possible error, and thus how much readjustment would be necessary. After readjustment check again!

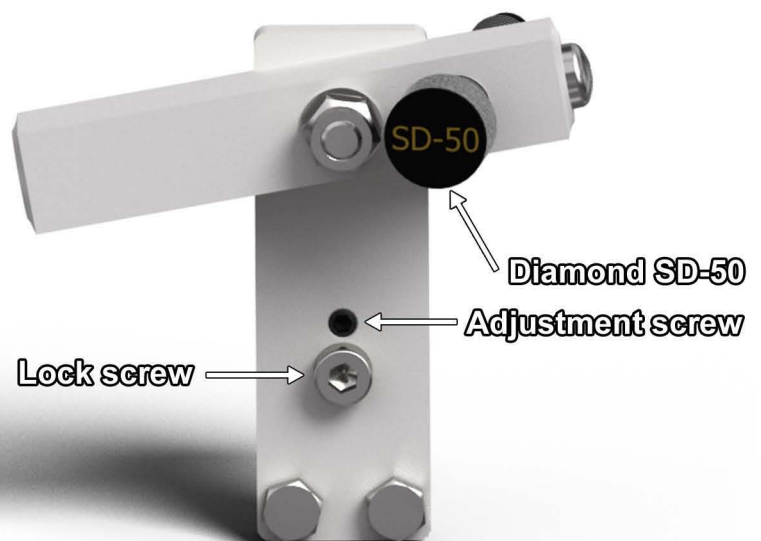



# OPERATION (continued)

## SHARPENING THE SKATE (advice)

### Dress grinding wheel

Connect the machine to the power source and start it (*using the power switch 5*). Use the diamond (*8b or 9b*) to dress the grinding wheel so that it will give the desired shape to the blade (flat or with desired hollowness).

If the grinding wheel feels blunt, you should dress it even if the shape is not to be changed.

*Hollow sharpening: Ice hockey skates and Figure skates*

*Flat sharpening: Bandy skates and Touring skates*

### Correct any damage on the skate blade

Check the skate blade for damage. If massive damage is found, use a whetstone to get the blade even on the sides.

Then fasten the skate in the skate holder.

Sharpen it at least twice with constant pressure applied against the grinding wheel, see figure:

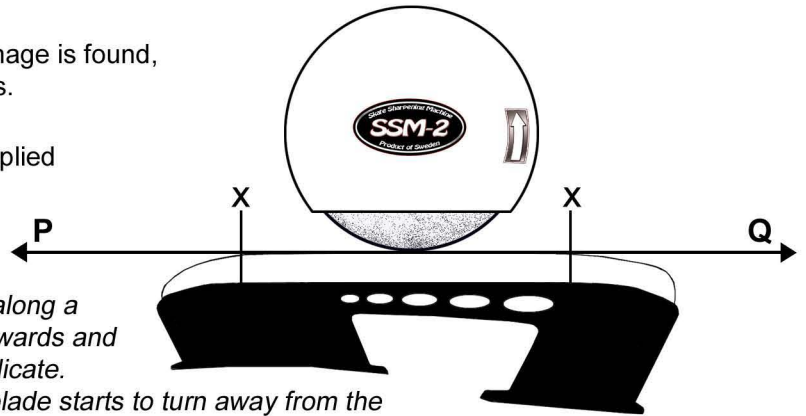

*When sharpening, keep the skate blade directed along a straight line (PQ in the figure). Move the blade forwards and backwards in the same direction as the arrows indicate.*

*The two "X" points in the figure marks where the blade starts to turn away from the grinding wheel. Start the sharpening movement "in the air" outside an X-point. Then make a smooth contact with the grinding wheel. At the other X-point the skate will turn away from the grinding wheel. Continue the movement a bit without having contact with the grinding wheel before turning back and doing the movement in the other direction.*

Check for any remaining damage. If damage is found, repeat the sharpening until all damage or wear is gone.

### Final sharpening

When no damage remains on the skate blade, sharpen the whole blade including the round ends slowly and smoothly. Use light pressure to get a better micro finish and to avoid removing too much material from the round edges. Perform the movement as shown below in one continuous sequence. The tables can be moved in the X and Z direction and cannot be rotated.

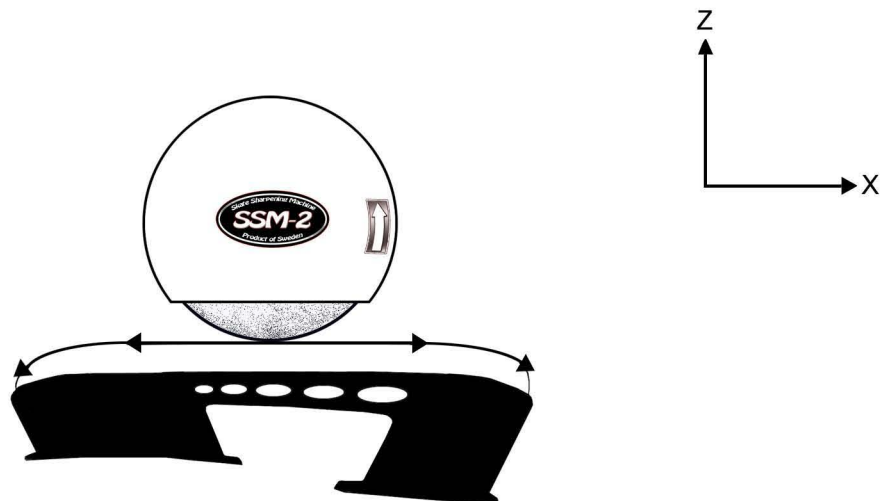

### Finish

Use a flat whetstone approximately twice on each side of the blade to remove any abrasive wounds.

### **ATTENTION!**

*Do not move the skate too slowly against the grinding wheel and do not apply too much pressure against it. The skate blade may be "burnt" because too much heat is generated locally!*

*When sharpening, keep your hands on the skate holder. Do not let the skate carry the weight of your hands. Otherwise the skate blade will tilt from the horizontal plane.*



# MAINTENANCE

## HOW TO CHANGE AND BALANCE THE GRINDING WHEEL

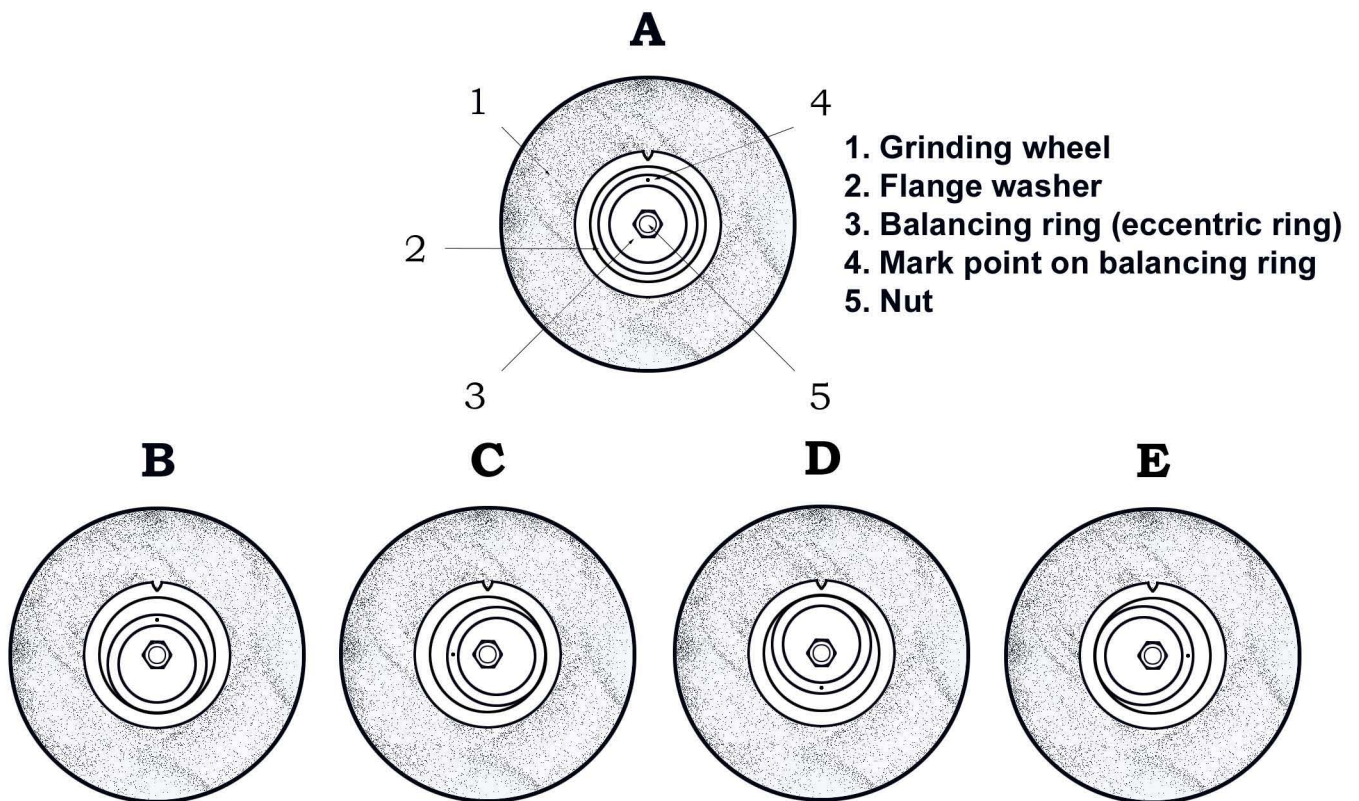

1. First test the grinding wheel for cracks. Hold the wheel on a finger (through the center hole) and gently tap on it. By listening to the sound you can check whether the wheel contains cracks. Remove the protective cover, the nut, the balancing ring, the flange washer and the old grinding wheel. (To avoid wobbling of the grinding wheel, remember to thoroughly clean flange, flange washer and grinding wheel mounting surface before mounting.) Then put the new grinding wheel on top of the flange. Put the flange washer and then the balancing ring on top (in the neutral position, i.e. centered with the mark point in the 12 o'clock direction). Fasten the nut with the grinding wheel having some selected mark (selected by you) in the 12 o'clock direction. Start the engine and dress the grinding wheel with one of the diamonds. Don't forget to have the protective cover on! If the grinding wheel vibrates, adjust using the following scheme. (The grinding wheel will impart vibrations to the whole machine. They are most easily felt at the end of the guide arm at the skate holder.)
2. Stop the engine and direct the grinding wheel in the 12 o'clock direction. Loosen the nut and move the balancing ring somewhat in the 6 o'clock direction (i.e. an eccentric position). Fasten the nut and restart the engine. Remember how much the grinding wheel vibrates (*Fig. B*).
3. Do as in step 2, but with the mark point in the 9 o'clock, 6 o'clock and 3 o'clock directions. The amount of eccentricity of the balancing ring should be kept the same (*Figs. C, D, E*).
4. If there are fewer vibrations in some direction, turn the balancing ring so that its mark point has that direction. If two directions give fewer vibrations than the others, put the mark point direction between the two. Then fasten the grinding wheel with the balancing ring adjusted. Start the engine and dress the grinding wheel. If the grinding wheel still vibrates, make a precision adjustment.
5. If a precision adjustment is needed, move the balancing ring in small amounts to be more centered or more eccentric or change the direction of its mark point slightly. Start the engine, dress the grinding wheel and test if the vibrations lessen. This is an iterative procedure. It should be possible to adjust until the vibrations practically disappear.

## MAINTENANCE (continued)

### SERVICE

If the machine is used correctly and only for sharpening skates then service is seldom needed. However, the grinding wheel and diamonds should regularly be replaced. The grinding wheel should be replaced when the distance between its outer diameter and the front edge of the protective cover has decreased to approximately 10 mm. (When the diameter of the grinding wheel goes below 120 mm, the grinding wheel should be replaced to give a good result.) To retain the capacity of the machine and to continue to get a good result, always keep the machine clean. Clean the outside. Remove dust with a soft brush if needed.

**WARNING!** A complete service should always be performed by a qualified technician. When performing maintenance yourself (e.g. replacing grinding wheel or diamonds) ensure that the electric plug is disconnected. To avoid danger, work on electrical parts should always be done by a qualified technician.

For power tools with type Y attachment: if the replacement of the supply cord is necessary, this has to be done by the manufacturer or his agent in order to avoid a safety hazard.

## TECHNICAL SPECIFICATIONS AND DIMENSIONS

<b>HEIGHT:</b>	<b>390 mm</b>
<b>WIDTH:</b>	<b>450 mm</b>
<b>LENGTH:</b>	<b>740 mm</b>
<b>WEIGHT:</b>	<b>32 kg</b>
<b>POWER:</b>	<b>250 W</b>
<b>VOLTAGE:</b>	<b>220-240 V</b>
<b>FREQUENCY:</b>	<b>a.c. (1-phase) 50-60 Hz</b>
<b>MAXIMUM RPM:</b>	<b>2800-3400 RPM</b>

<b>GRINDING WHEEL TYPE:</b>	<b>Type S-2 from SSM</b>
<b>GRINDING WHEEL DIMENSIONS:</b> (Diameter * Thickness * Arbor)	<b>150 x 6 x 38 mm</b>

<b>DIAMOND:</b>	<b>For flat sharpening: SD-50, SD-80 or D-80</b> <b>For hollow sharpening: SD-80 or D-80</b>
-----------------	---

**THE MACHINE IS INTENDED FOR INTERMITTENT USAGE (on 60s / off 60s).**

**Your SSM Produkt AB distributor:**



# ACCESSORIES

## GRINDING WHEELS

**S-2/60**



*Pink*  
Grit size 60  
Standard wheel

**S-2/HP70**



*Yellow*  
Grit size 70: special  
For professional teams

**S-2/ME60**



*Pink/purple*  
Grit size 60: ceramic  
Excellent on all steels

**S-2/K80**



*Light blue*  
Grit size 80: ceramic  
For professional teams

## DIAMOND DRESSERS

**D-80**



Natural diamond  
For:  
Pivot device &  
Flat surface device

**SD-80**



Synthetic diamond  
For:  
Pivot device &  
Flat surface device

**SD-50**



Synthetic diamond  
For:  
Flat surface device

## WHETSTONES OR HAND HONES

**B-SSM**



From silicon carbide  
One fine grit size  
Size: 75x18x10 mm

**BB-SSM**



From silicon carbide  
Same mixture as B-SSM  
Size: 75x25x10 mm

**CB-SSM**



From aluminum oxide  
Two different grit sizes  
Size: 75x18x10 mm

**DB-SSM**



Diamond hand hone  
Precision tool  
Handle with care!  
Size: 75x25x5.5 mm

## EXHAUST SYSTEMS

**U-840**



Welding fume exhaust  
Very high quality  
Uses the U-324 filter

**NQS500**



Dust extractor  
Very powerful and quiet motor  
Uses a cyclone intake